



72 Little Francis Street Collingwood VIC

 2
  1
  1

You'll Love, The Look, The Light & The Lifestyle?

6 Months Lease Only

Architecturally innovative & designed for sophisticated living, is this youthful residence with its own lock up garage and designated home office room. It's just a stone's throw to Johnston Street attractions and walking distance to Smith & Gertrude Street's loved lifestyle amenities, making it perfect for lovers of urban living.

Offering an unexpected sense of privacy over 3 exciting levels, it's very suave light filled interior features totally independent zones which offers, dedicated living & dining zones which both connects to two outdoor retreats, edgy & cool kitchen well-equipped with dishwasher, 2 bedrooms that share a double shower bathroom on the top level and a separate home office on the lower level perfectly zones work life away from home.

Other highlights include: Auto garage, alarm system,

Type : Townhouse
Date Available : Friday, 5th August 2022
View : <https://www.thebisiagent.com.au/lease/vic/inner-city/collingwood/residential/townhouse/7664073>

John Bisignano
 03 9489 1030

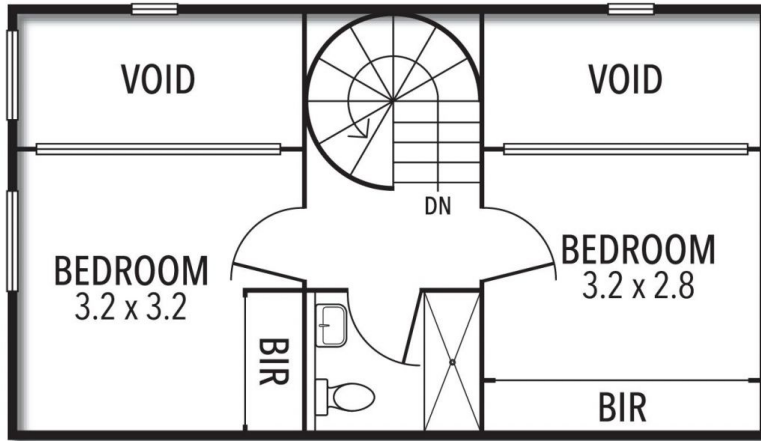

SECOND FLOOR

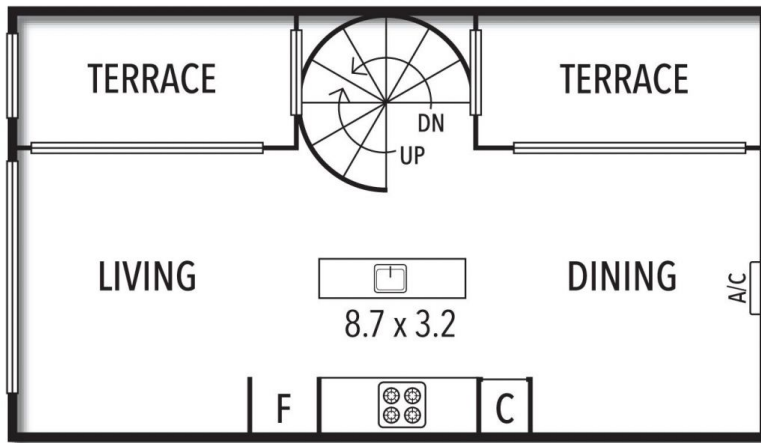

FIRST FLOOR

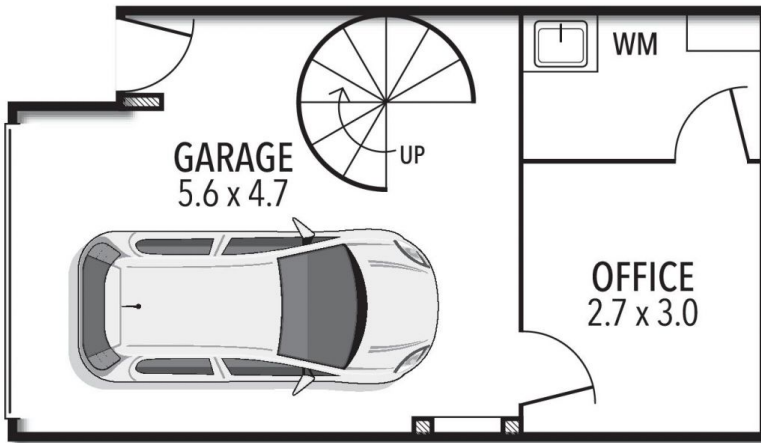

GROUND FLOOR



THE ABOVE PLAN IS AN ARTIST'S IMPRESSION ONLY, IT INCLUDES ELEMENTS THAT ARE FOR DISPLAY PURPOSES ONLY AND MAY NOT BE TO SCALE. LANDSCAPING SHOWN IS INDICATIVE ONLY. DIMENSIONS ARE APPROXIMATE.